

RA12

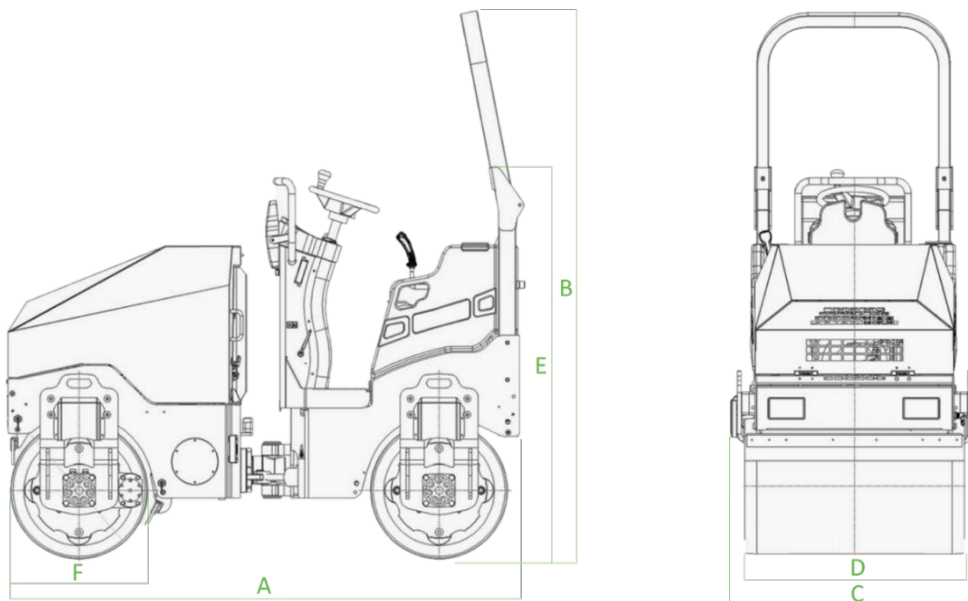

RA12 Technical Specifications

Weight	RA12
Operating Weight	2640 lb
Performance Data	
Drum Thickness	0.5 in
Vibration Frequency	4000 vpm
Centrifugal Force (front drum)	3825 lbf
Travel Speed with Vibration	4.5 mph
Gradeability Maximum	30%
Water Tank Capacity	31.7 gal
Engine	
Engine Manufacturer	Honda
Engine Model	GX630
Cooling	air -cooled
Number of Cylinders	2
Output Power	20.8 HP
Operating Speed	3600 rpm
Fuel Tank Capacity	5 gal



Dimensions

Overall Length	A	74.5 in
Overall Height	B	83.25 in (86 in with beacon strobe)
Overall Width	C	40 in
Drum Width	D	35.5 in
Height ROPS Folded	E	57.5 in
Drum Diameter	F	22 in

Standard Equipment

- Hydrostatic drive & vibration
- Hydrostatic articulated steering
- Oscillating articulation joint
- Pressurized water system
- Folding ROPS
- Back-up alarm
- Strobe beacon
- Work lights front & rear
- Parking brake
- Seat belt
- Hour meter
- Fuel gauge