

3CE RA45 Electric Schematic

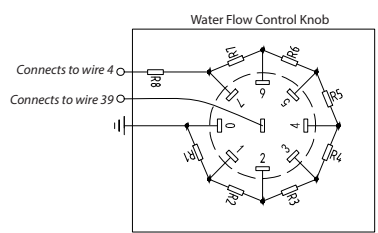
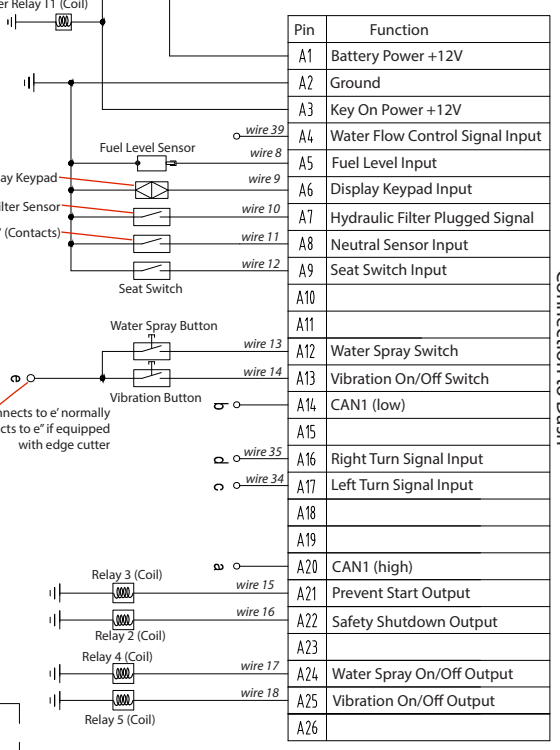
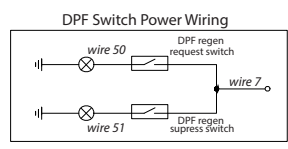
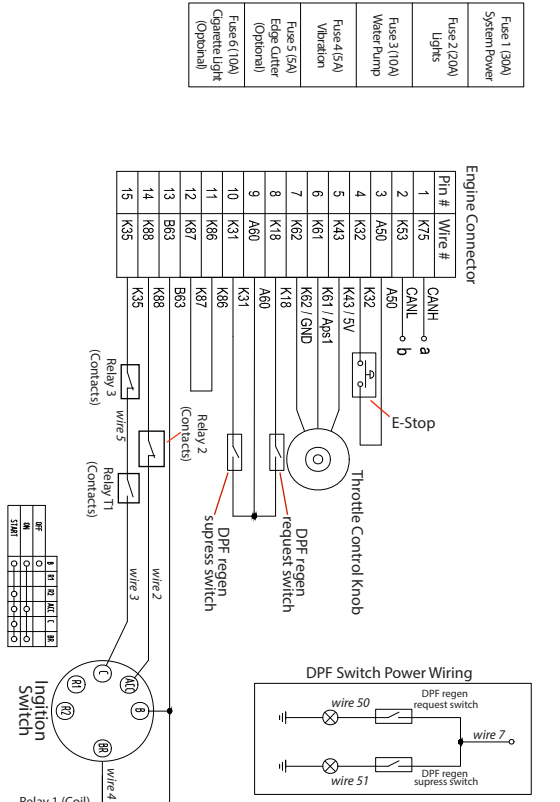
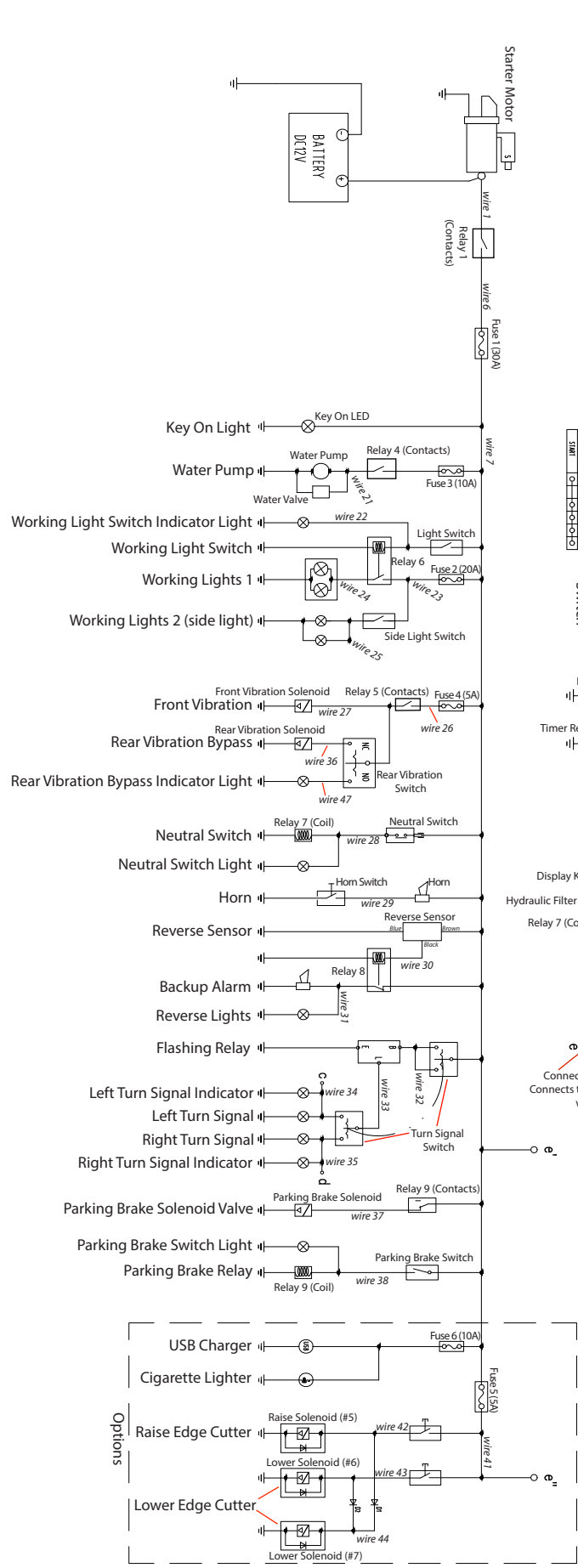

R1=R3=R5=R7=220 Ω
 R2=R4=R6=120 Ω
 R8=2200 Ω

Fuse 1 (30A)
System Power
Fuse 2 (20A)
Lights
Fuse 3 (10A)
Water Pump
Fuse 4 (5A)
Vibration
Fuse 5 (5A)
Edge Cutter (Optional)
Fuse 6 (10A)
Cigarette Lighter (Optional)