

Soil Roller RS35



Operator's Manual

**THIRD
COAST**
EQUIPMENT



THIRDCOASTEQUIPMENT.COM

©2025 by Third Coast Equipment, Inc. All rights reserved.

All trademarks referenced in this manual are the property of their respective owners.

No portion of this manual may be reproduced without written permission from Third Coast Equipment, Inc.

To reduce the risk of injury, all operators and maintenance personnel must read and understand their machine's instruction manual in full before operating, changing accessories, or performing maintenance on that machine.

CONTENTS

Introduction	1
Applications	1
Safety Labeling	2
Hazards & Risks	4
California Proposition 65 Warning	4
General Hazards & Risks	4
Transportation Hazards	4
Mechanical Hazards	5
Fire, Explosion & Thermal Hazards	5
Chemical Hazards	5
Noise Hazards	6
Personal Protective Equipment & Human Health Hazards	6
Additional Hazards	6
Operation	7
Familiarization with the Soil Roller & its Components	7
Joystick Control Operation	7
Daily Pre-Operation Inspection	8
Starting the Roller	8
Operating the Soil Roller	8
Fore/Aft Travel	8
Engine Speed	9
Operating the Exciters	9
Operating the Dozer Blade	9
Powering Off the Roller	9
Emergency Shutdown Procedure	9
Adding or Removing the Padfoot Drum Covers	9
Tips for Proper Compaction	10
Extended Storage	11
Lifting & Transportation	11
Care & Preventative Maintenance	12
Machine Inspection Intervals	12
Engine Inspection & Maintenance Tables	13
Tightening Torque Tables	14
Service Parts & Fluids Tables	14
Specifications	15
Machine Specifications	15
Engine Specifications	16
Standard Equipment & Accessories	16
Troubleshooting	16
Wiring & Hydraulic Diagrams	18
Warranty	19

INTRODUCTION

Thank you for your purchase of this Third Coast Equipment, Inc. ("Third Coast") soil roller. Please read this operator's manual in its entirety prior to using your new machine. This manual provides information pertaining to the safe use, proper operation, and routine maintenance of this machine. All operators and maintenance personnel must read and understand this manual in full before operating, changing accessories, or performing maintenance on this machine.

This manual is written for Third Coast machines in production at the time of publication, and Third Coast reserves the right to change any portion of this manual at any time without notice to reflect any changes to current production machine configurations or updates to regulatory compliance or for any other reason deemed appropriate by Third Coast.

The latest revision of this manual can be obtained by visiting us online at:

THIRDCOASTEQUIPMENT.COM

APPLICATIONS

Compaction is an essential step in construction; proper ground preparation is critically important in setting a base for any structure, whether that structure be a road; residential, commercial or industrial building; footing or pier; retaining wall; deck; or even a simple concrete sidewalk.

Any time earth is disturbed, whether through trenching, digging, excavation, or addition of gravel substrates, it must be compacted before building commences.

Proper compaction ensures the ground is prepared to handle the weight of the structure above it by increasing the packing factor of ground solids, eliminating unnecessary air, and reducing compressibility. Proper mechanical compaction reduces the chances that the ground will shift or further compress, thereby increasing the load capacity of that ground, reducing the risk of frost heave, and increasing structural stability of the improvements above it.







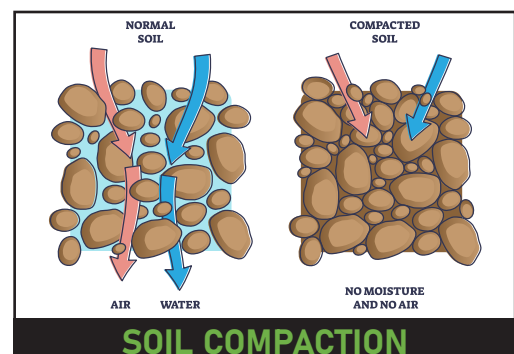

Soil rollers feature a heavy-duty steel drum that vibrates under high frequency to consolidate the ground beneath it. These heavy-duty rollers feature a front drum and rear tires, giving more traction than a double-drum roller to navigate the toughest jobsites. Soil rollers are ideal for difficult to compact cohesive soils and easily navigate steep grades, ensuring a solid substrate for construction. Featuring significantly more weight and vibratory power than walk-behind compactors, this roller is ideal for compacting roadways, building sites, and other large-scale construction projects.

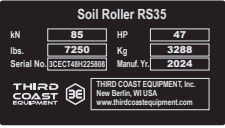
Soil rollers are ideal for:

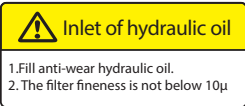
- Compacting granular & mixed soils
- Gravel/aggregate compaction
- Roadway preparation

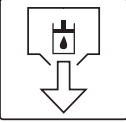

MACHINE LABELS

LABEL	INTERPRETATION
	<p>NAMEPLATE: Lists important information about the machine including model, serial number, and other information.</p>
	<p>TIE DOWN: This label identifies safe tie-down points for securing the machine for transport.</p>
	<p>HYDRAULIC OIL: This label indicates the presence of hydraulic oil.</p>
	<p>HYDRAULIC OIL INLET: This label contains information about filling the hydraulic oil tank.</p>
	<p>HOT SURFACE: This label warns of a high temperature surface that can cause burns if touched.</p>
	<p>LIFT POINT: This label identifies the safe lifting point for transporting the machine.</p>
	<p>HYDRAULIC OIL DRAIN: This label identifies the drain port for emptying hydraulic oil.</p>
	<p>DIESEL HAZARDS: This label warns of the presence of diesel fuel and the hazard an open flame presents.</p>
	<p>PINCH POINT: This label warns of a pinching hazard present at the articulation joint.</p>
	<p>EYE & HEARING HAZARDS: This label indicates to wear eye and hearing protection while working on or near this machine.</p>
	<p>EMERGENCY STOP: This label indicates the location of the emergency stop button.</p>

Labels continued on next page.

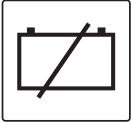
LABEL	INTERPRETATION
	READ THE MANUAL: This label instructs the operator to read the manual prior to operating the machine.
	BATTERY DISCONNECT: This label indicates the location of the battery disconnect switch.

HAZARDS & RISKS

CALIFORNIA PROPOSITION 65 WARNING

 **WARNING** Use of this product may expose you to certain chemicals, including diesel engine exhaust, which are known to the State of California to cause cancer.

GENERAL HAZARDS & RISKS

 **WARNING** General hazards are those that do not fall under a specific hazard classification, or that relate to multiple hazard classifications.

- Ensure all operators read and understand the operator's manual prior to using this machine.
- Never operate or allow anyone else to operate this machine without understanding the operational and safety controls of this machine. Even after reading the manual, new operators should receive instruction from an experienced operator.
- Never leave a machine operating while unattended.
- Use only accessories recommended by Third Coast. Any non-approved accessories may lead to operator injury or machine damage.
- Inspect this machine before every operation and at the required intervals listed in the "Care & Preventative Maintenance" section.
- Clean the machine during and after each use to ensure all safety labels remain legible. Replace any illegible safety labels before continued operation.
- Serious injury can result from improper or careless use of this machine.
- Keep this machine out of the reach of children at all times, including when not in use.

TRANSPORTATION HAZARDS

 **WARNING** Failure to adequately secure this machine while transporting and failure to lift with proper technique can result in damage to the equipment or injury or death.

- Inspect all lifting hardware (both on this machine and all ancillary lifting equipment) prior to lifting this machine.
- Never lift this machine while it is operating.
- Ensure the fuel cap is tight prior to lifting or transporting this machine.
- Only lift this machine with proper load-rated straps or slings rated for the weight and application.
- Never stand or work under a lifted machine.
- This machine is heavy. Lift using auxiliary equipment only. Do not attempt to lift this machine manually.
- Ensure a clear path to your destination and stable and clear ground before lifting.

MECHANICAL HAZARDS

⚠ WARNING Certain mechanical hazards are inherit in operating this machine due to the weight, operation, travel, and vibration of this machine. Disregarding these warnings can lead to serious injury.

- Do not operate this machine unless all protective guards are in place.
- Keep hands and feet clear of rotating and moving parts.
- Ensure the machine is OFF before removing the guards or making adjustments or repairs.
- Ensure the machine and the operator are set up on stable ground while in operation or service.
- Do not leave this machine unattended while in operation.
- When working in trenches, ensure adequate trench shoring is used to prevent collapse.
- Ensure the area in which you are working does not contain any live electrical cables, gas, water, or communication services that may be damaged by this equipment.
- Never stand on the unit while it is operating.
- Do not increase the governed no-load motor speed above 2,400 rpm; personal injury and damage to the machine may result.
- All machine and engine repairs should be conducted by a certified servicing dealership.

FIRE, EXPLOSION & THERMAL HAZARDS

⚠ WARNING Internal combustion engines contain diesel fuel and generate heat that poses certain hazards.

- Diesel fuel is extremely flammable and explosive under certain conditions.
- Ensure diesel fuel is only stored in an approved storage container.
- Do not refuel while the engine is operating or hot.
- Do not refuel in the vicinity of sparks or open flame.
- Do not refuel in confined spaces. Vapors may concentrate and ignite.
- Only fuel this machine on the ground. Do not fuel in truck beds or other areas where static electricity may be present.
- Do not overfill the fuel tank.
- Ensure the fuel cap is securely fitted after refueling.
- Avoid spilling diesel when refilling; spilled diesel or diesel vapors may ignite. If spillage occurs, clean the area per local environmental regulations prior to resuming operation.
- Avoid contact with the engine and muffler while this machine is running or while it is hot. Extreme heat may cause severe burns.
- Do not operate this product in enclosed spaces or modify it in any way that reduces engine cooling. Never attempt to restrict airflow over the engine cooling fins.
- Do not operate this machine off of gasoline; use only diesel fuel rated for Tier 4f engines.

CHEMICAL HAZARDS

⚠ WARNING Certain chemical hazards exist due to the presence of diesel, grease, oil, and other chemicals presented by the combustion process including carbon monoxide, a colorless, odorless gas that can cause death if inhaled. Failure to follow the below instructions may lead to severe injury or death.

- Do not operate in a confined space or without adequate ventilation. Carbon monoxide exhaust gases from internal combustion engine driven equipment can cause death in confined spaces.

- Do not refuel this machine in confined spaces. Diesel vapors may be hazardous to your health, and concentrated vapors may cause an explosive atmosphere.
- Any fluids spilled from the machine, whether flammable or not, must be cleaned up in a manner consistent with all local environmental regulations.
- Always use approved fluids when maintaining or servicing this machine. Improper fluids may lead to poor performance or failures of the machine and may create a hazardous situation for the operator or bystanders. Dispose of all fluids properly in accordance with local regulations.

NOISE HAZARDS

⚠ WARNING This equipment exceeds the Occupational Safety & Health Administration (“OSHA”) safe noise levels and can cause temporary or permanent hearing loss.

- Wear an approved hearing protection device while operating this machine as required by OSHA regulations to limit noise exposure.
- Bystanders may also require hearing protection, depending on their distance to the machine.
- Always be visually aware of your surroundings. While operating this machine, you may not hear other auditory warnings from nearby equipment. Heightened awareness is required.

PERSONAL PROTECTIVE EQUIPMENT & HUMAN HEALTH HAZARDS

⚠ WARNING Proper personal protective equipment and operating practices are important to minimize the inherent hazards that this machine presents.

- Always wear proper protective clothing when operating this equipment, including hearing protection, respiratory protection, shatterproof eye protection, safety-toe boots, and other personal protective equipment (“PPE”) as required by OSHA or local regulations.
- Control silica dust at the source when possible using water or other suppression means.
- Exercise care when operating this unit. Exposure to vibration or repetitive work actions may be harmful to the hands and arms.
- Slip/trip/fall hazards are a major cause of serious injury and death. Beware of uneven or slippery work surfaces.
- Exercise care when working in the vicinity of open trenches, holes, or excavations.
- Never operate this equipment under the influence of drugs or alcohol. This includes prescription drugs without your doctor’s consent.
- Never operate this equipment when you are not feeling well.
- Do not attempt to operate this equipment when you are not in line of sight of the roller.

ADDITIONAL HAZARDS

⚠ WARNING It is not possible to document all of the scenarios that could result from misuse of this machine, and proper training, operation, and jobsite safety best practices should always be followed to minimize the occurrence and severity of all hazards.

- Only use this machine for its intended application.
- Always have an emergency preparedness plan, and practice it often.
- Always have a first aid kit and fire extinguisher on the jobsite. Ensure the fire extinguisher is rated for the applications, including fires caused by the combustion of gasoline and diesel.
- Do not work alone; always ensure someone else is on the jobsite with you.
- Know your jobsite address so you can give it to first responders in an emergency.

OPERATION

FAMILIARIZATION WITH THE SOIL ROLLER & ITS COMPONENTS

Prior to operating this soil roller, it is important to be aware of the critical components, safety features, and safe operating procedure of this machine.

BATTERY DISCONNECT SWITCH

The battery disconnect switch disconnects power from the battery to the roller and should be disengaged at the end of operation to safeguard against battery drainage. To disconnect, turn the switch to the OFF position. To re-enable the battery, turn the switch to the ON position (clockwise).

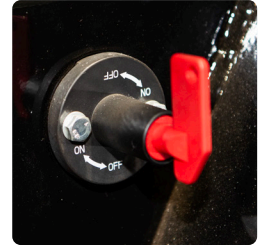

EMERGENCY STOP SWITCH

The Emergency Stop switch, located on the operator's right arm rest, stops all machine functions including the engine. The Emergency Stop should only be used in emergency situations. To engage the Emergency Stop switch, depress it. To release it, twist it clockwise until it pops outward.



LIGHTING CONTROL

This roller's lights function similar to most automobile lights: Turn the outer portion of the switch as shown by the arrow marked "2" below to engage the dash and/or worklights. Engage the signal lights by moving the entire lighting switch up or down as indicated by arrow "1" below.



DIESEL PARTICULATE FILTER REGEN

This roller's Yanmar engine DPF auto-regenerates during normal use. The operator may notice white smoke and a change in engine RPM; this is normal. Auto-Regen may be disabled by engaging the "Bypass Regen" switch on the dash panel, indicated by the icon to the right. If disabled for a long period, stationary regeneration will be required. Set the machine to low idle, apply the parking brake, and hold the "Active Regen" button indicated by the icon below for three seconds. Active regen takes 25 minutes and if skipped, the engine will require non-warrantable service. It is recommended to not engage the Bypass feature unless critical to your jobsite requirements.

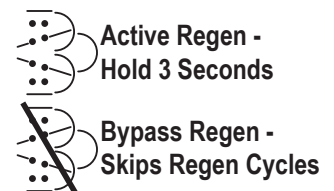

JOYSTICK CONTROL OPERATION

The joystick controls fore/aft travel, engages and disengages the compaction excitors, and raises or lowers the dozer blade (if equipped). Unless actively moving the roller forward or backwards, the joystick should remain in the neutral position, indicated by an "N".

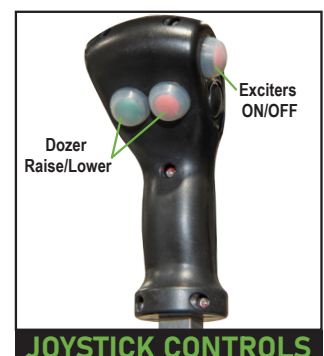

CONTROL PANEL

The control panel provides important operator feedback including engine conditions, machine status, and other critical metrics, as detailed below:

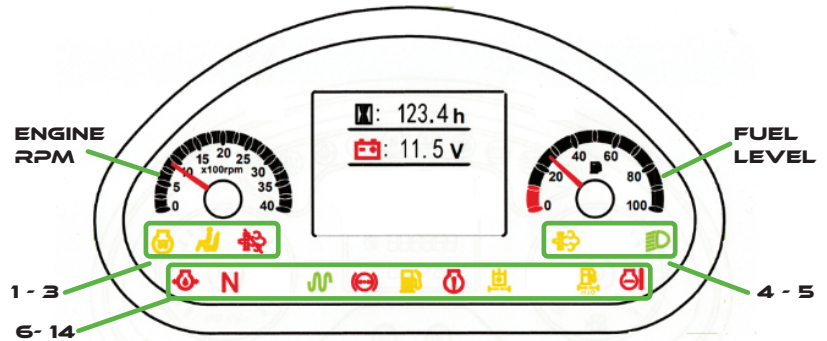

- | | | |
|---------------------|-----------------------------|----------------------------|
| 1. GLOW PLUG ON | 2. SEAT SWITCH | 3. DPF REGEN BYPASS MODE |
| 4. DPF REGEN ACTIVE | 5. LIGHTS ON | 6. LOW OIL PRESSURE |
| 7. NEUTRAL POSITION | 8. VIBRATION ON | 9. BRAKES ENGAGED |
| 10. LOW FUEL ALERT | 11. CHECK ENGINE | 12. CHECK HYDRAULIC FILTER |
| 13. WATER IN FUEL | 14. HIGH ENGINE TEMPERATURE | |

DAILY PRE-OPERATION INSPECTION

The following inspections must be completed prior to each daily use of the roller and again after every four hours of machine operation:

- Visually inspect the machine for signs of damage. Remove any dirt, debris, or material that may have accumulated from prior use.
- Check all hardware to ensure proper tightness. See the “Care & Preventive Maintenance” section for proper fastener torque.
- Check the engine oil level, engine coolant level, and hydraulic oil level, and refill as needed.
- Check for fuel and hydraulic oil leaks, and repair as needed.

STARTING THE ROLLER

- Ensure the area around the roller is free from personnel, debris, and other potential hazards prior to mounting the roller.
- Ensure the engine speed is in the  position, the Emergency Stop is disengaged, the drive is in the NEUTRAL “N” position, and the battery disconnect is in the “ON” position prior to starting the roller. The roller will not start if these conditions are not met.
- Sit in the operator’s seat and fasten the seat belt before starting the roller.
- Adjust the steering column to a comfortable position by depressing the foot pedal and pushing or pulling the column to the desired location.
- Turn the roller key one click away from you to cycle the glow plug, and wait approximately five seconds. The glow plug icon on the dashboard will illuminate when the glow plug is active.
- Turn the key to the START position and hold it until the engine starts, then release the key.
- Turn on the dashboard illumination lights or the LED work lights, if desired.
- Allow 2-3 minutes for the roller to warm up; your roller is now ready to operate.



OPERATING THE SOIL ROLLER

FORE/AFT TRAVEL



When ready to move the roller, disengage the parking brake by depressing the bottom of the parking brake switch (P) on the dashboard. Basic fore/aft motion of the roller is controlled by

the joystick at the operator's right arm position. The control is position-sensitive and will travel faster in either direction the further away the lever is from the "N" neutral position. To travel forwards, push the joystick first to the left to disengage it from its neutral position, then towards the front of the machine. To travel in reverse, push the joystick first to the left to disengage it from its neutral position, then towards the rear of the machine.

ENGINE SPEED

The speed of the engine can be adjusted by turning the knob just behind the fore/aft joystick from the low speed () position to the high speed () position, or anywhere between as desired. As a general rule of thumb, drive speed and compaction force will increase with increased RPM.

OPERATING THE EXCITERS

To engage the compaction exciters, first select high or low vibration by toggling the exciter switch to either high vibration () or low vibration () mode. Next, start the exciter motor by depressing the exciter ON/OFF switch on the joystick control. To stop the vibration, depress the exciter ON/OFF switch on the joystick control again.

OPERATING THE DOZER BLADE

If equipped with the optional dozer blade, this blade can be raised or lowered by using the "Dozer Raise" and "Dozer Lower" buttons on the joystick control.

POWERING OFF THE ROLLER

To power off the roller after use:

- Disengage the vibration by depressing the joystick Exciter OFF button.
- Set the engine to low speed by positioning the throttle knob to the  position.
- Shut off the engine by turning the key to the OFF position.
- Engage the parking brake by depressing the parking brake button.
- Turn off the lights.
- If the roller will not be used for a while, disconnect the power by turning the battery disconnect switch to the OFF position.

EMERGENCY SHUTDOWN PROCEDURE

The machine is equipped with an Emergency Stop button that will stop all machine functions immediately when engaged, including shutting down the engine. To engage the Emergency Stop, depress the Emergency Stop button  fully. To release the Emergency Stop, turn the Emergency Stop button clockwise until it stops and pops slightly outward. The Emergency Stop is for emergencies only and should not be used for shutting down the roller in non-emergency situations.

ADDING OR REMOVING THE PADFOOT DRUM COVERS

Padfoot covers bolt directly over your existing drum. To install the padfoot drum cover, lift the front of the machine (see "LIFTING & TRANSPORTATION") and slide one half of the drum cover under the smooth drum. Ensure the smooth drum is clean, or it may not fit properly. Next, place the other half over the top of the drum and secure the six bolts per the torque specifications listed in the "TIGHTENING TORQUE TABLES" section.

TIPS FOR PROPER COMPACTION

Soil rollers are fast, efficient tools for compacting a wide variety of substrates. The chief concern when operating a roller is safety, and several precautions should be followed during operation.

First, walk the jobsite prior to starting your equipment to make sure it is free of people, foreign objects, obstructions, trip hazards, and other obstacles that may impede operation or cause a safety concern. The operator is always responsible for safe operation and ensuring there are no people or objects in the roller's path.

Proper compaction is extremely important, as it eliminates extraneous air in the substrate and reduces the transport of air and water, resulting in a more stable base with less chance of shifting or settling. Soil rollers impose extremely high forces on the ground to ensure adequate compaction, and with any high-powered device, it is possible to overdo it and cause an over-compacted substrate, which is actually weaker for building on and can yield long term failures. Your best resource regarding proper jobsite compaction is always your jobsite engineer. If you have a jobsite engineer, always follow their specification for proper compaction.

If you do not have a jobsite engineer, you can ensure the best possible compaction with these helpful rules of thumb:

- Don't overdo it. Cracking soil indicates over-compaction. Over-compaction can break down the soil itself, resulting in a much weaker substrate than properly compacted soil. Over-compaction can also cause premature wear and tear to your roller, shortening its life.
- As you gain experience with this machine, you will understand the noises it emits and how they relate to under-compaction, proper compaction, and over-compaction. The guidance of a more experienced operator can help you build this experience, but a general rule of thumb is that over-compaction will be noisy with excessive and more erratic machine vibration. Such motion can also cause premature wear to your roller.
- Count your passes in each area, and track your areas closely. Uniform compaction is equally as important as the right amount of compaction and helps prevent uneven settling.
- If in doubt of your lift requirements, a good rule of thumb is a lift height of 14" for sand and gravel, 10" for mixed soils, and 6" for clay and silt (without the padfoot shell) or 8" for clay and silt (with the padfoot shell). For very dry soils, reduce lift to 75% of the recommended height. It is better to have a lower lift and fewer passes than to try to compact too large a lift with more passes.
- If in doubt of your local conditions, use a field test apparatus such as a dynamic cone test to ensure your soil is properly compacted prior to building.

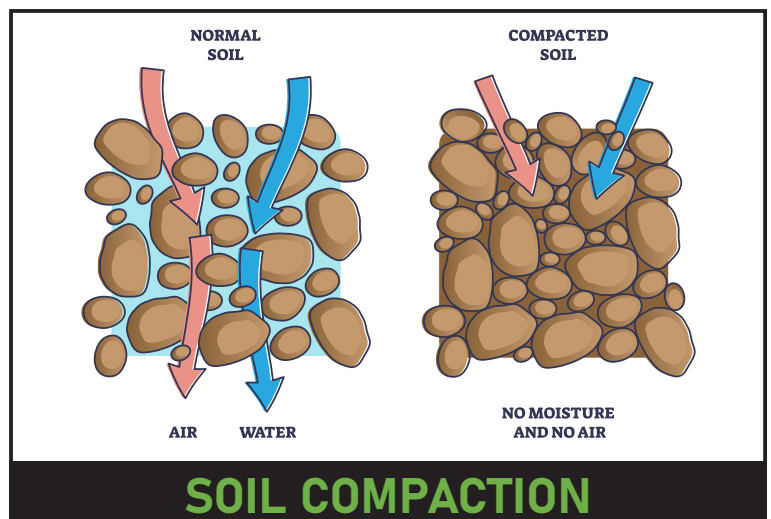

EXTENDED STORAGE

Following proper long-term storage procedures ensures the machine is ready to operate when you return to it. The following procedures should always be performed when the machine will not be in use for the next 30 days:

- Thoroughly clean the exterior of the machine with a damp rag, then dry it. Do not use solvents.
- Check and repair any leaks and tighten any loose hardware prior to storage.
- Check the engine oil and hydraulic oil levels, and top off if necessary.
- Check the engine coolant level, and top off if necessary.
- Clean the fuel filter, and drain the water from the fuel/water separator if necessary.
- Clean or replace the air filter.
- Store the machine in a clean and dry indoor storage location.

LIFTING & TRANSPORTATION

Safe lifting practices must always be followed when moving this roller over long distances to and from the jobsite and when moving it short distances around the jobsite.

PRIOR TO LIFTING YOUR MACHINE:

- Power down the machine.
- Ensure all hardware, including the fuel cap, is secure on the machine. Tighten any loose bolts.

TO LIFT THIS MACHINE:

- Use a four-point lift strap or hook rated for the weight.
- Attach the lift strap through the four indicated lifting points. All four lifting points must be used.
- Lift straight upwards, never at an angle, and never lift higher than necessary.
- Never walk underneath the machine when lifted.

TO TRANSPORT THIS MACHINE:

- When transporting over the road, always tie down the machine using straps of adequate strength secured through the two front and two rear tie-downs.
- Always use multiple straps to secure this machine.
- When transporting across the jobsite using the roller's own power, always use smooth, controlled movements and a speed appropriate to the terrain. To ascend hills, position the roller straight uphill; avoid cross-slope climbs to reduce the risk of tipover.

NOTE: The lift point and tie downs on this machine are symmetrical about the centerline in the image shown on the right.

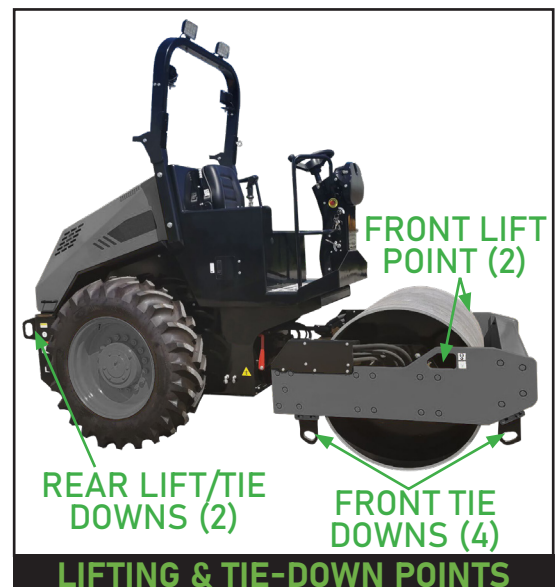

CARE & PREVENTATIVE MAINTENANCE

Third Coast soil rollers are designed to provide years of trouble-free service, but as with all power equipment, periodic maintenance is required to keep this machine running smoothly. Maintenance is a normal part of ownership of any machine, and must be carried out on time per the prescribed intervals or sooner, as needed. Please note, this operator's manual is not a service guide. All service should be done by a qualified, trained service technician.

CAUTION Inspection and other service should always be carried out on hard, level ground with the engine shut down.

MACHINE INSPECTION INTERVALS

This roller must be inspected, at a minimum, at the intervals described in the "Machine Maintenance/Inspection" table below. In tough operating environments, more frequent inspection is recommended.

MACHINE MAINTENANCE/INSPECTION	
ITEM	OPERATION HOURS
Basic operation check	Every 8 hours or every day
Full visual inspection	Every 8 hours or every day
Inspect engine accessory V-belt	Every 8 hours or every day
Check hydraulic and engine oil levels	Every 8 hours or every day
Grease articulation joint & steering cylinder	Every 40 hours or weekly
Inspect scraper bar for wear, replace as needed	Every 200 hours or monthly
Exciter oil	Lifetime lubrication; no service needed

DAILY OPERATIONAL CHECKS

Prior to each daily use of the equipment and at the start of each operator's shift:

- Visually inspect the machine for signs of damage. Remove any dirt, debris, or material that may have accumulated from prior use.
- Clear any dust accumulation from the air filter, engine cooling fins, articulation joint, and in the control panel.
- Check all hardware to ensure proper tightness. See the "Tightening Torque Tables" section for proper fastener torque.
- Check the engine oil level, hydraulic oil level, and coolant level, and refill as needed.
- Check for fuel and oil leaks, and repair as needed.
- Check the engine coolant level, and refill as needed.

WEEKLY OPERATIONAL CHECKS

After each week of operation, or each 40 hours, whichever occurs first:

- Grease the articulation joint (both top and bottom pins) with NLGI No. 2 synthetic multipurpose grease.
- Grease the steering cylinder (both ends) with NLGI No. 2 synthetic multipurpose grease.

MONTHLY OPERATIONAL CHECKS

After each month of operation, or each 200 hours, whichever occurs first:

- Inspect the scraper bars for wear and cracks. If necessary, adjust the scraper bar to provide for a 1/4" to 3/8" clearance from the drums.

ENGINE INSPECTION & MAINTENANCE TABLES

To maximize the lifespan of your engine, inspect and maintain it per the schedule in the "Engine Maintenance" table below. This table is an excerpt from the engine manufacturer's manual and is not a substitute for reading your engine manual in its entirety.

ENGINE MAINTENANCE	
ITEM	OPERATION HOURS
Inspect for oil leakage	Every 8 hours or every day
Check oil level	Every 8 hours or every day
Check for loose or missing hardware	Every 8 hours or every day
Replace engine oil	First change: 50 hours Second change: 250 hours Thereafter: Every 500 hours
Clean or replace air filter	Every 500 hours, or as needed in dustier environments
Replace fuel filters	Every 500 hours

A complete list of required engine maintenance tasks can be found in your engine manual.

TIGHTENING TORQUE TABLES

The threaded fasteners on this machine are all right handed, coarse-thread, metric, Class 8.8 or Class 12.9 fasteners.

All fasteners on this machine are marked by strength class and must be torqued to the proper specification for that class. To identify whether a fastener is a Class 8.8 or Class 12.9 fastener, check the identifying marks stamped on the head.



CLASS 8.8 FASTENER



CLASS 12.9 FASTENER

TIGHTENING TORQUE FOR CLASS 8.8 FASTENERS								
THREAD SIZE>	M6	M8	M10	M12	M14	M16	M18	M20
TORQUE, FT-LB>	7	17	34	59	94	146	210	292
TORQUE, N·M>	9.5	23	49	80	127	198	285	395

TIGHTENING TORQUE FOR CLASS 12.9 FASTENERS								
THREAD SIZE>	M6	M8	M10	M12	M14	M16	M18	M20
TORQUE, FT-LB>	11	26	51	88	139	210	285	401
TORQUE, N·M>	15	35	69	119	188	285	386	544

SERVICE PARTS & FLUIDS TABLES

SERVICE PARTS & FLUIDS		
ITEM	PART/TYPE	QUANTITY
Exciter Oil	Mobil SHC629	2.1 qt (2L)
Engine Oil	15W-40	6.9 qt (6.5L)
Hydraulic Oil	AW ISO 46 Hydraulic Oil	17.2 gal (65L)
Axle Planetary Gear Reduction	85w90 GL-5 Gear Oil	1.3 qt (1.2L) per side
Differential Oil	85w90 GL-5 Gear Oil	5.1 qt (4.8L)
Exterior Engine Air Filter	Donaldson P822768	1
Interior Engine Air Filter	Donaldson P822769	1
Fuel Filter	Yanmar 129A00-55800	1
Fuel/Water Separator Element	Yanmar 129A00-55730	1
Engine Oil Filter	Yanmar 129150-35170	1

SPECIFICATIONS

MACHINE SPECIFICATIONS

TABLE 5: SOIL ROLLER SPECIFICATIONS	
DIMENSIONS & WEIGHT	
Wheelbase ("A")	71 in
Drum Width ("B")	47.2 in
Overall Length ("C")	131 in
Drum Diameter ("D")	47.2 in
Overall Width ("E")	53 in
Height, ROPS Folded ("H1")	74 in
Height, ROPS Extended ("H2")	108 in
Operating Weight, lb	7,250
PERFORMANCE DATA	
Vibration Frequency, vpm	2,460
Centrifugal Force, lbs	High: 19,109 Low: 9,667
Travel Speed (with vibration), mph	5.6
Gradeability Maximum	55%
Drum Thickness, in	0.6
Drive	Hydrostatic

Note: Roller and engine specifications are both subject to change at any time.

DIMENSIONS REFERENCE DIAGRAMS

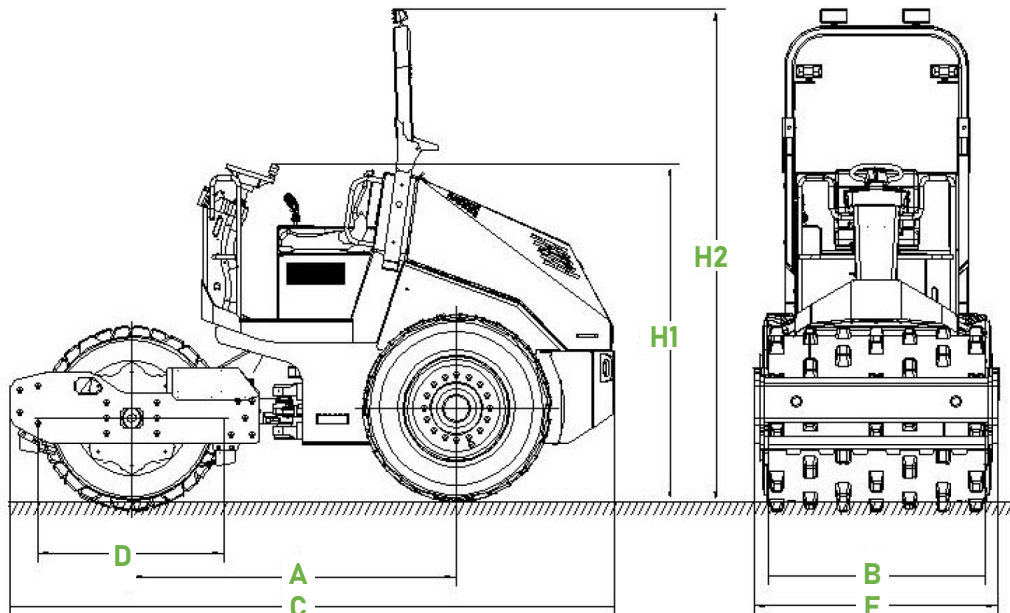

ENGINE SPECIFICATIONS

This machine features a Yanmar Tier 4f diesel engine. Full engine specifications can be found in your Yanmar engine manual, but key specifications are summarized below for convenience:

TABLE 6: ENGINE SPECIFICATIONS	
ENGINE DATA	
Engine Manufacturer	Yanmar
Engine Model #	4TNV88 - Diesel
Cooling	Liquid Cooled
Number of Cylinders	4
Output Power, hp	47
Operating Speed, rpm	2,400
Fuel Tank Capacity, gal	13.2

STANDARD EQUIPMENT & ACCESSORIES

Standard equipment:

- Poclain hydraulic drive motors
- Danfoss hydraulic exciter motor
- Comfort all-weather awning kit
- Folding ROPS with seat belt
- Working lights
- Strobe & reverse beacons
- Mirrors
- Drum scrapers

Optional accessories:

- Padfoot drum shell
- Hydraulic dozer blade

Contact your Third Coast Equipment dealer for more information on accessories.

TROUBLESHOOTING

SYMPTOM	POSSIBLE CAUSE	SOLUTION
Engine does not start and will not turn over.	Battery disconnect is in OFF position.	Turn battery switch to ON position.
	Operator is not in the seat.	Ensure operator is in the seat before starting, and that operator presence light on dash is not illuminated.
	Battery is not charged.	Check for at least 12V indicated on the voltmeter on the dash when the key is in the ON position. Charge or replace roller battery.
	Emergency Stop is engaged.	Disengage Emergency Stop by twisting it counterclockwise.
	Loose battery wires.	Check that both red and black main battery wires are tightly connected to the battery.
	Loose wire connection at starter.	Check that the large red wire is connected tightly at the starter terminal.
	Travel lever not in neutral position.	Move to neutral position and retry.

SYMPTOM	POSSIBLE CAUSE	SOLUTION
Engine does not start; it turns over but will not maintain operation.	Low engine oil.	Check oil level and refill as needed.
	Low fuel level or bad fuel.	Check fuel level and age of fuel.
	Inadequate glow plug cycle time.	Cycle glow plugs for five seconds, and try starting engine again.
	Water in the fuel.	Check fuel/water separator. If necessary, drain fuel system and refuel.
	Plugged fuel filters.	Check sight glass on fuel filters for debris. Replace filters if necessary.
	Air is trapped in the fuel system.	Crack open fuel lines at fuel pump and each injector. Bleed air out of lines and retighten fuel lines.
Engine is difficult to start, or will not remain running at idle.	Low fuel level or bad fuel.	Check fuel level and age of fuel.
	Water in the fuel.	Check fuel/water separator. If necessary, drain fuel system and refuel.
	Plugged or partially plugged fuel filters.	Inspect fuel filters and replace if necessary.
	Air is trapped in the fuel system.	Crack open fuel lines at fuel pump and each injector. Bleed air out of lines and retighten fuel lines.
	Engine is very cold.	Extend glow plug cycle time and try starting again.
Engine shuts off after being operated for a long period of time.	Low fuel level or bad fuel.	Check fuel level and age of fuel.
	Plugged fuel filters.	Check sight glass on fuel filters for debris. Replace filters if necessary.
	Oil level too low. Low oil cut off engaged.	Check oil level. Refill if necessary.
	Air filter plugged.	Check air filter for dirt. Replace if necessary.
	Machine battery drains because the charging circuit is faulty.	Check the charging circuit is providing >13.5V when the engine is running at high speed.
Engine operates normally but will not transmit power to the drums.	Low hydraulic oil level.	Check hydraulic oil level with sight glass on tank. Refill if necessary.
	Parking brake engaged.	Disengage parking brake using the toggle switch on the dashboard.
	Travel control cable disconnected	Turn off machine, then verify that moving the travel control lever causes movement in both the control cable and at the pump lever arm.
	Leaking hydraulic hoses.	Check for leaks in the hydraulic hoses and fittings. Repair if necessary.

WIRING & HYDRAULIC DIAGRAMS

WIRING DIAGRAM

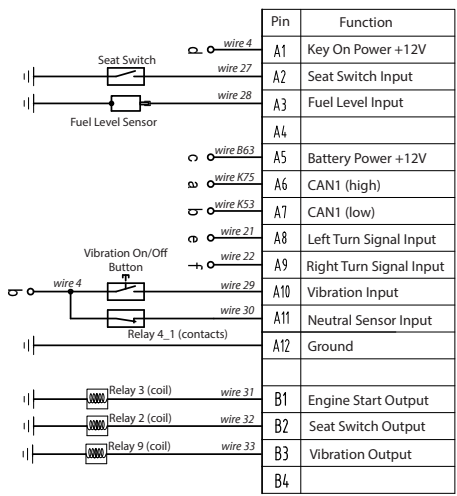
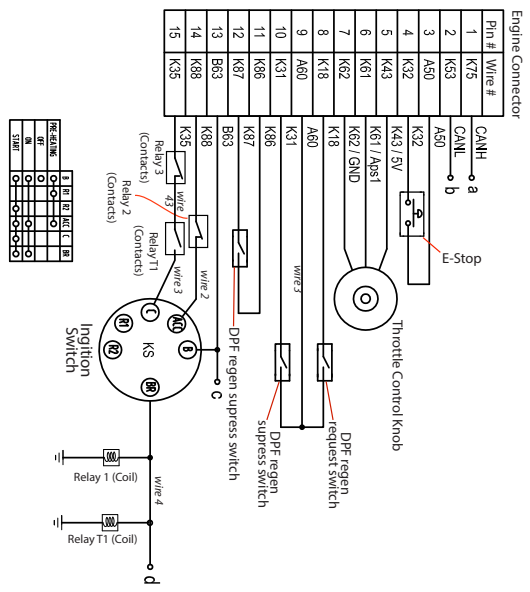
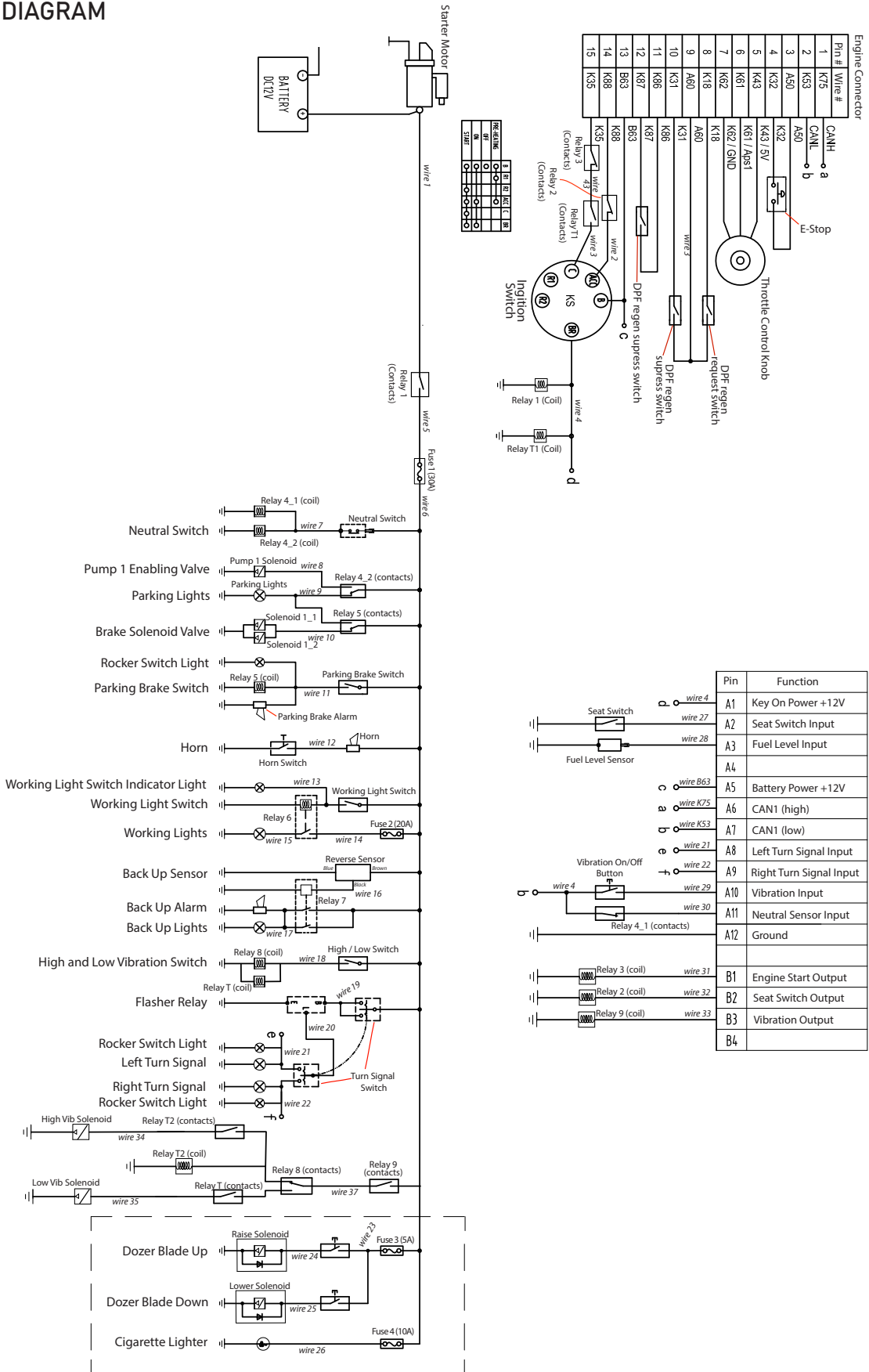

HYDRAULIC DIAGRAM

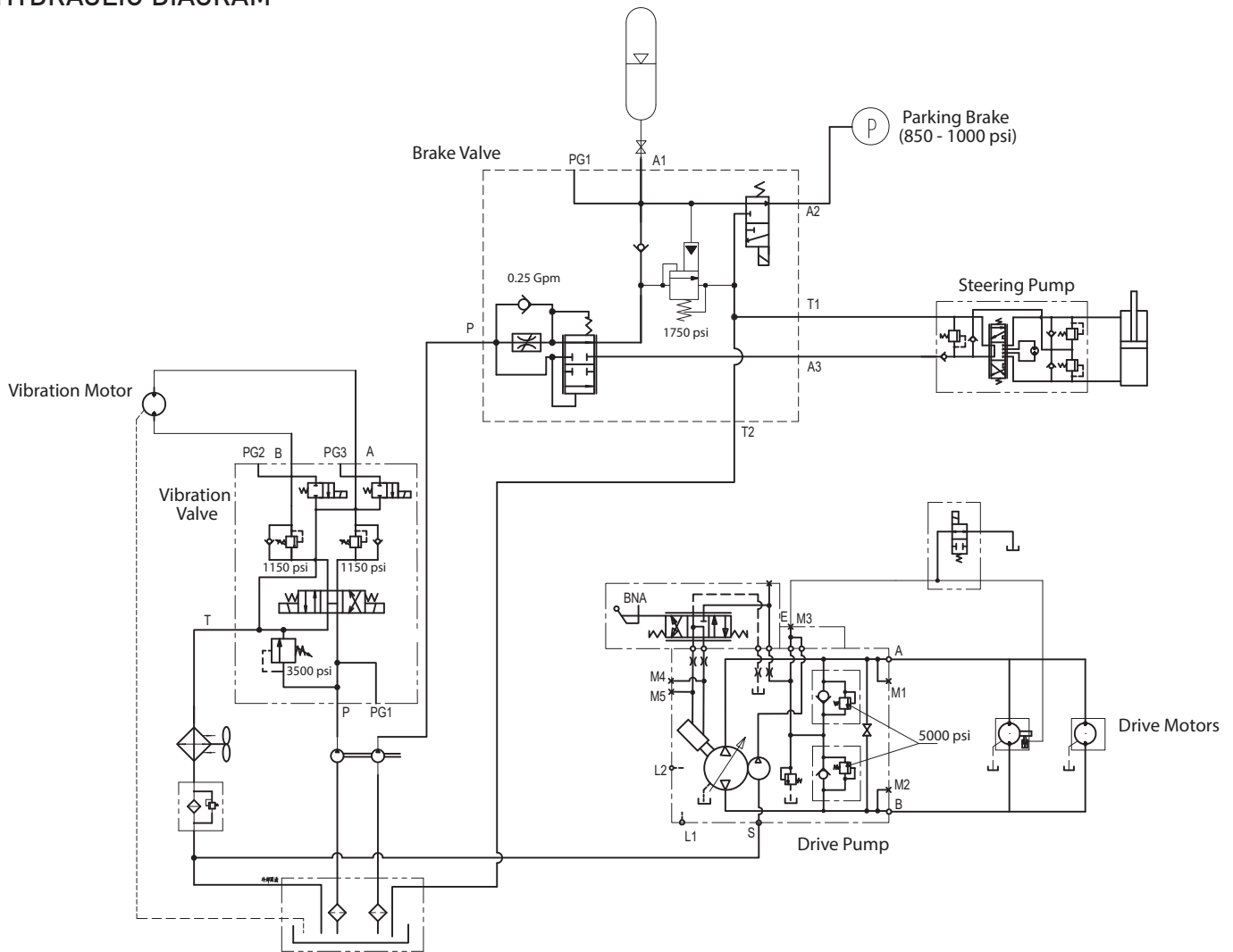

WARRANTY



Third Coast Equipment stands behind all of its products with a best in class warranty, including:

- Five-year warranty on spare parts
- Four-year warranty on Vanguard engines
- Three-year warranty on Honda engines
- Two-year warranty on labor

This limited warranty contains certain exclusions and limitations and is restricted to repair or replacement of the machine or affected parts only. Other exclusions may apply.

To view the full Third Coast Equipment warranty policy, visit:

[HTTPS://THIRDCOASTEQUIPMENT.COM/WARRANTY-POLICY](https://thirdcoastequipment.com/warranty-policy)

THIRD COAST EQUIPMENT



3CE Dealer Card

THIRD COAST EQUIPMENT, INC.
NEW BERLIN, WI
THIRDCOASTEQUIPMENT.COM



RS35-0M-01